

LED EMERGENCY BATTERY PACK

Output Voltage 15V to 55V Constant Current 73mA **Max 4W**

Compact Low Profile for Use with AC Driver 8A Max and LED Module with 15-55V Output

Universal Voltage 120-277V Electronic LED Emergency Battery Pack for Constant Current LED Driver 0-10V Dimming with one wire Test Switch/LED Indicator for easy installation. Output Range of 15V to 55V for 4W maximum.

Technical Specification:

UL, CUL Certified, ROHS Compliant

Rating: IP30

Battery Type/Model Number: LiFePO4 6.4V 1500mAh



Case Size: E10

Due to continuing efforts to offer improved products all specifications are subject to change without prior notice

OPERATING DURATION	INPUT CURRENT	INPUT WATTS	Battery Charge Current	Battery Voltage	Battery Charge Time Max	OUTPUT WATTS	OUTPUT CURRENT Max	OUTPUT VOLTAGE	MODEL
90 Minutes	60mA	4	185mA	6.4V	24 hours	4	73	15 to 55V	EM4W1555B64E10

LIMITED WARRANTY

5 YEAR at maximum case temperature 60 deg C. 3 YEAR at maximum case temperature 66 deg C. 3 YEAR for battery. Manufacturer warrants to the purchaser: Product will be free from defects in material or workmanship from the date of manufacture conditioned upon proper storage, installation, use, and maintenance and conformance with any recommendations of Manufacturer

Lead Length

Colour	inch	cm
Black	5.9	15
White	5.9	15
Blue	5.9	15
Red	5.9	15
Yellow/Black	5.9	15
Yellow	5.9	15
Brown	5.9	15
Test SW/LED Indicator	30.7	78

LED INDICATOR / TEST SWITCH MOUNTING DIMENSIONS

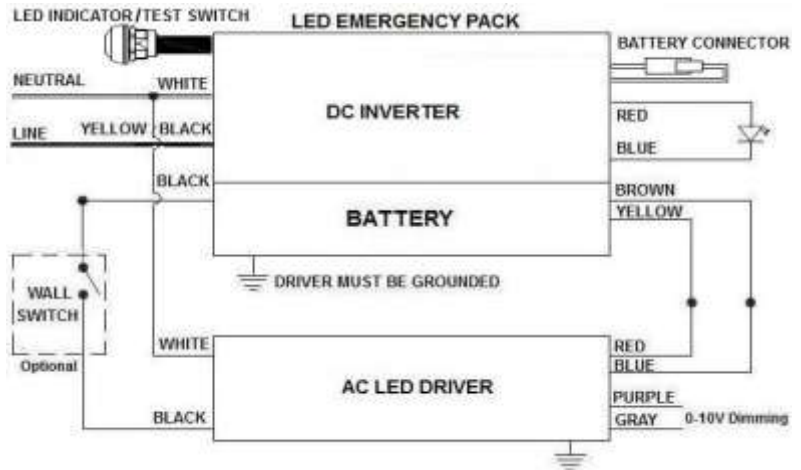
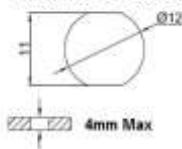

Series E10	L	W	H	ML
Case Size:	420mm	30.8mm	27.8mm	412mm
	16.5inch	1.21inch	1.09inch	16.22inch

WARNING: Always Disconnect Power Before Handling.
Case Should be Grounded. Install in Accordance with National and Local Electrical Codes.

